

Safety Warnings

- The filter should only be operated while submersed in water to avoid any hazard of electrical shock and risk of damage.
- Do not run dry or above water level.
- Do not operate the pump if there is any damage to the electrical cord.
- Always cut off the power when the pump/ filter is not in use.
- Do not attempt to repair a damaged pump/ filter.
- The pump/ filter is for aquarium internal use only.
- Use only properly rated extension cord, otherwise the motor may be damaged.

Feature (A) : Low Flow Rate

- Plug in the nozzle to the water outlet of the Pump/ Filter.

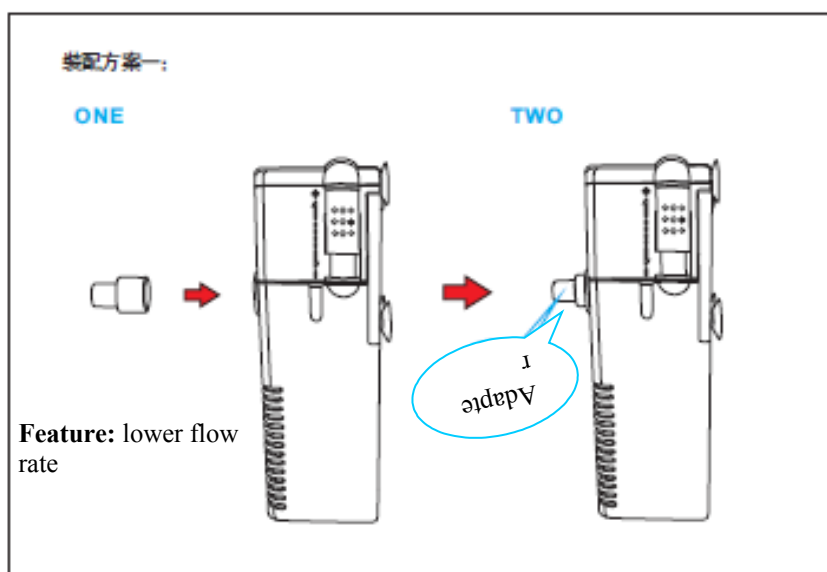

Feature (B) : Medium Flow Rate

- Plug in the nozzle to the water outlet of the Pump/ Filter.

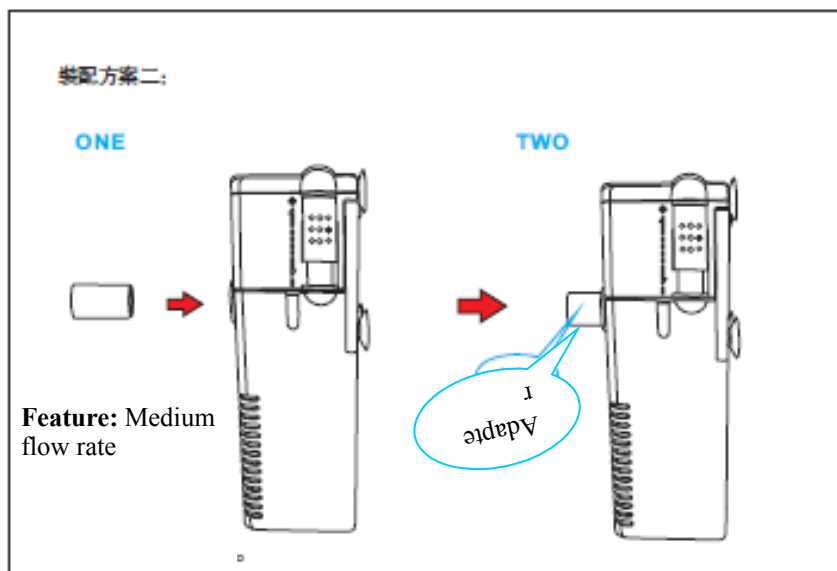

Feature (C) : Rotated Nozzle

- Plug in the rotated nozzle (as per sketch) can adjust the flow direction.

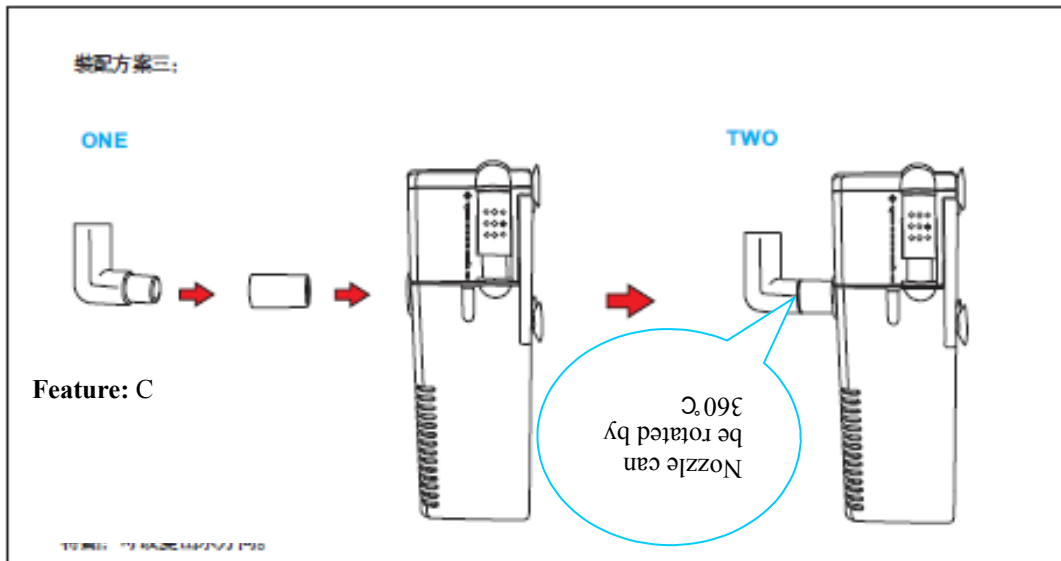

Feature (D) : Waterfall Effect

- Add the cover to the water outlet of the Pump/ Filter.

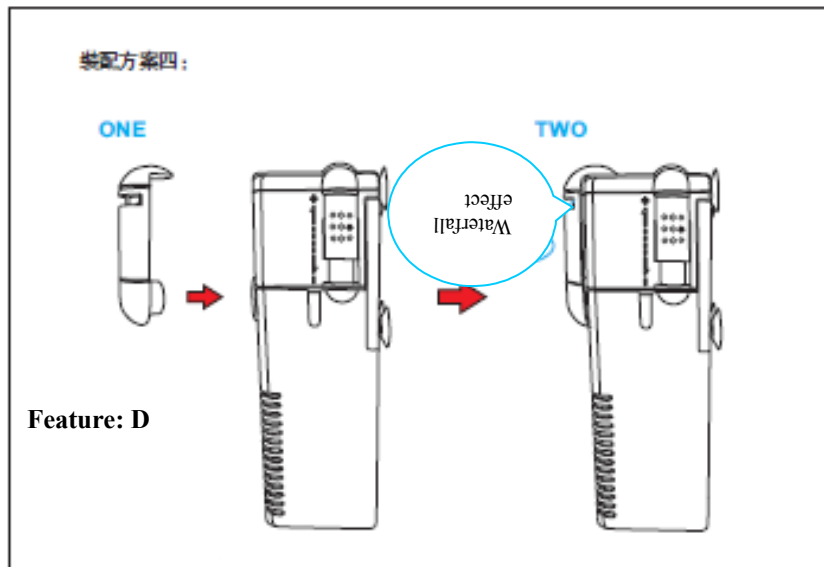

Feature (E) : Spray Effect

- Insert spray bar into the curved nozzles of the Pump/ Filter

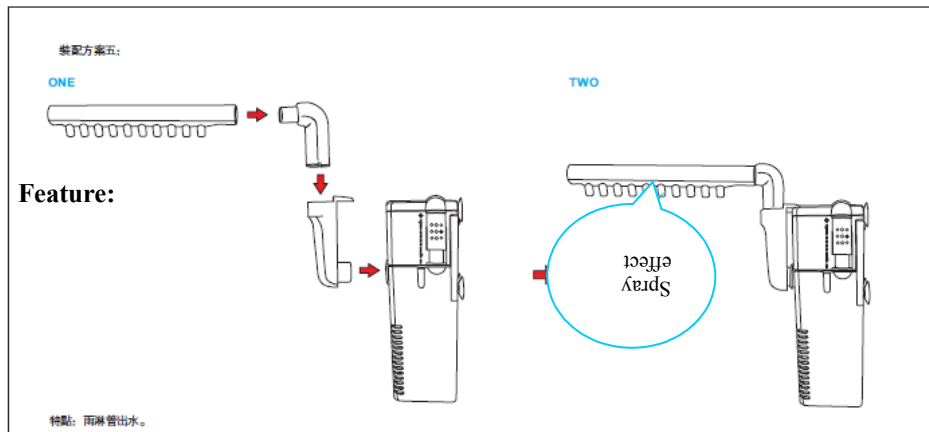

Feature (F) : Air Induction

- Connect air tube to the Venturi and Adapter as per sketch, Venturi placed outside the tank and it helps to increase aeration.

